

Introduction

The LTE communicator is a plug-in cellular communication module that connects the PowerMaster control panel to the Cloud, PowerManage server, and to private phones. LTE enables a high-speed and highly reliable primary or backup communication channel. If LTE network is not available, the panel can switch to 3G WCDMA or 2G/GPRS data channel.

The LTE communicator is compatible with PowerMaster-10, 30, and 33 G2 control panels, installed with software version 18 and later.

Box contents

Before you begin, verify that the box contains the following components:

- An LTE communicator in an ESD package.
- Installation instructions.
- Screw kit.

Pre installation instructions

Before you begin the installation, complete the following step:

- For panels with version 19 and later, ensure that the network type option is set to **automatic**.

Installing the LTE communicator — quick overview

Step	Reference
1. Disconnect the panel from AC power.	
2. Open the panel and disconnect the battery.	See section Opening the panel and disconnecting the battery.
3. If installed, remove the installed cellular communicator from the panel.	
4. Mount the LTE communicator to the panel.	See section Mounting the LTE communicator to the panel.
5. Install the SIM card.	See section Inserting the SIM Card.
6. Connect the battery and close the panel.	See section Reconnecting the battery and closing the panel.
7. Connect the panel to AC power.	
8. Verify that the installation was successful.	See section Verifying installation.

Opening the panel and disconnecting the battery

1. To open the panel, use a screwdriver to release the screws. See the following figure for example of PowerMaster-33 panel.

Figure 1: Opening the panel

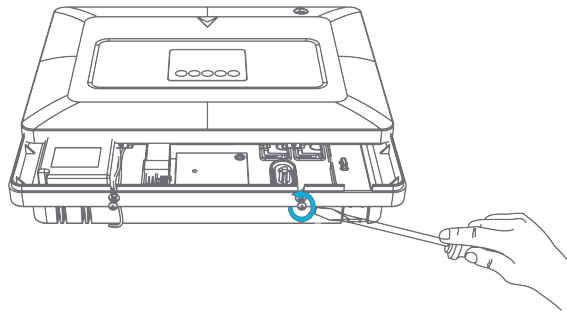

2. Use minimal force to remove the front cover from the back base of the panel.
3. Disconnect the battery connector.

Figure 2: Battery connector

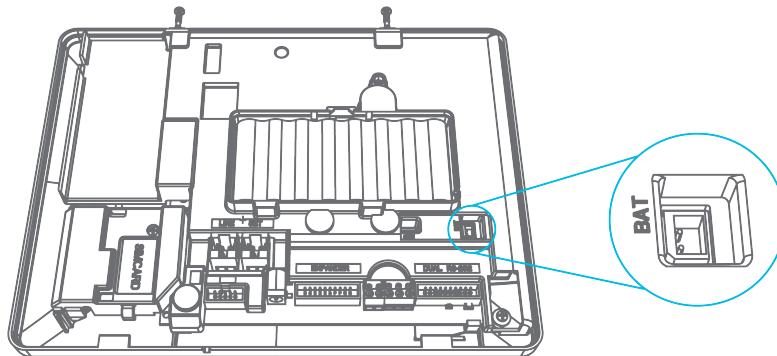

Mounting the LTE communicator to the panel

1. If installed, remove the installed cellular communicator from the panel.
2. Plug in the LTE communicator.
3. Fasten the screw to hold the communicator in place.

Figure 3: Mounting the LTE communicator

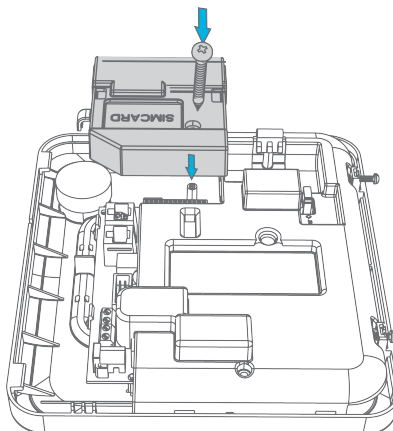

Inserting the SIM card

► **Important:** Do not insert the SIM card when the control panel is connected to AC power or when the battery is inserted.

1. Slide up the top cover.
2. Open the cover.
3. Align the SIM card in the cover. When cover is closed, the SIM card's gold contacts face down.
4. Slide the SIM card into the cover.
5. Rotate the cover to close.
6. Lock the cover.

Figure 4: Inserting the SIM card

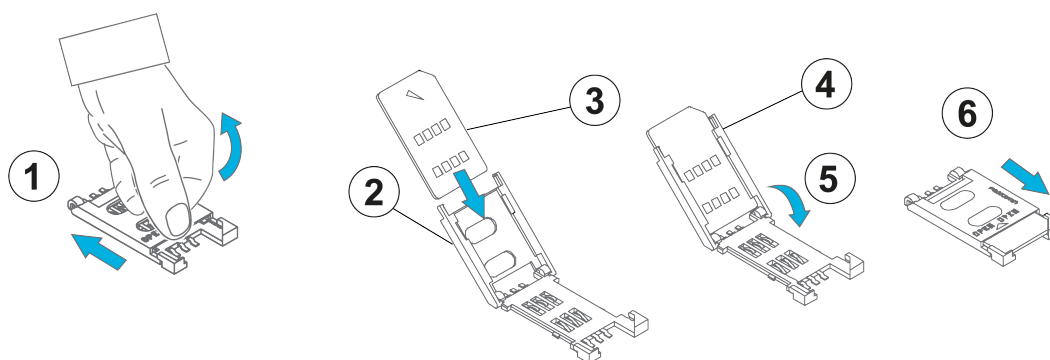

Reconnecting the battery and closing the panel

1. Reconnect the battery connector.
2. Place the front cover of the panel on the back case of the panel.
3. Close the panel and fasten the two screws. See the following figure for example of PowerMaster-10 panel.
4. Connect the panel to AC power.

Figure 5: Closing the panel

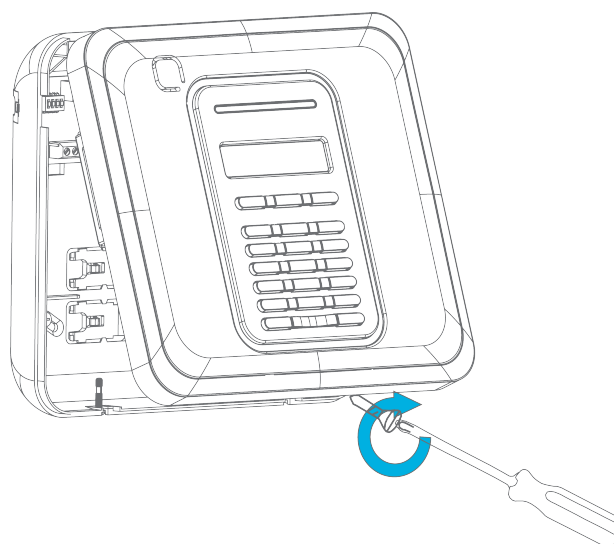

Verifying installation

1. From the **Diagnostic** menu, select **GSM/GPRS**.
 2. To initiate the GSM diagnostic test, press **OK**. If the installation is successful, the message `Unit is OK` is displayed.
 3. For panels with software version 19.0 and later, complete the following steps:
 - a. On the **show status** screen, check the cellular provider name and network type described in the following table. Any of these displays indicate successful installation. 2G or 3G will be displayed if the provider does not support LTE or if LTE is not available in the network.
- ⓘ **Note:** The first nine characters of the operator's name or code are displayed.

Table 1: Cellular provider name and network type

Display	Meaning
2G-LTE-<operator's name>	The communicator is registered to a 2G network.
3G-LTE-<operator's name>	The communicator is registered to a 3G network.
-LTE-<operator's name>	The communicator is registered to a 4G network.

- b. Check that the **Cellular Modem Model (> Installer Mode > 10: Serial Number)** displays an LTE suffix.

Optional: Mounting the external cellular antenna

⚠ WARNING: If you need to remove the external antenna, hold the connector but not the cable, and pull it out. This prevents damage to the PCB.

1. Install the external antenna on the chosen location on site.
2. Push out the removable insert (A).
3. Connect the external antenna to the connector on the LTE module (B).

Figure 6: Location of LTE external antenna connector in module and removable insert in panel

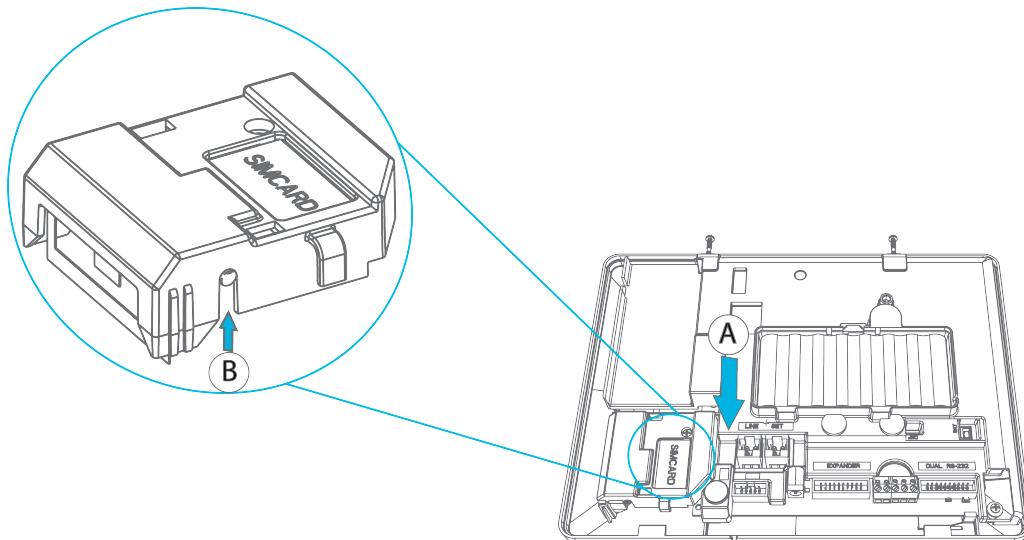

Technical data

Table 2: Modem types and bands

Modem type	Bands
LE910-EU v2, for 868 MHz and 433 MHz panels	GSM/GPRS: 900, 1800 MHz WCDMA: 900, 2100 MHz LTE: 2100, 1800, 2600, 900, 800 MHz
LE910-NA v2, for 915 MHz panels	WCDMA: 850, 1900 MHz LTE: 1900, 1700, 850, 700 MHz

Please refer to additional technical specifications on the website.

Compliance with standards

Compliance with European Standards: EN 301 489, EN 50130-4, EN 62368-1, EN 50136, EN 50131-10, 3GPP TS 36.521-1, EN 301 511, EN 301 908

Hereby, Visonic Ltd. declares that the radio equipment type LTE communicator is in compliance with Directive 2014/53/EU. The full text of the EU declaration of conformity is available at the following internet address: <http://www.visonic.com/download-center>.

Warranty

Visonic Ltd. (“**Seller**”) warrants the Products to the original purchaser only (the “**Buyer**”) against defective workmanship and materials under normal use of the Products for a period of twelve (12) months from the date of shipment by the Seller.

This Warranty is absolutely conditional upon the Products having been properly installed, maintained and operated under conditions of normal use in accordance with the Seller's recommended installation and operation instructions. Products which have become defective for any other reason, according to the Seller's discretion, such as improper installation, failure to follow recommended installation and operational instructions, neglect, willful damage, misuse or vandalism, accidental damage, alteration or tampering, or repair by anyone other than the Seller, are not covered by this Warranty.

There is absolutely no warranty on software, and all software products are sold as a user license under the terms of the software license agreement included with such Product.

The Seller does not represent that Products may not be compromised and/or circumvented or that the Products will prevent any death and/or personal injury and/or damage to property resulting from burglary, robbery, fire or otherwise, or that the Products will in all cases provide adequate warning or protection. The Products, properly installed and maintained, only reduce the risk of such events without warning and it is not a guarantee or insurance that such events will not occur.

Conditions to Void Warranty: This warranty applies only to defects in parts and workmanship relating to normal use of the Products. It does not cover:

- damage incurred in shipping or handling;
- damage caused by disaster such as fire, flood, wind, earthquake or lightning;
- damage due to causes beyond the control of the Seller such as excessive voltage, mechanical shock or water damage;

- damage caused by unauthorized attachment, alterations, modifications or foreign objects being used with or in conjunction with the Products;
- damage caused by peripherals (unless such peripherals were supplied by the Seller);
- defects caused by failure to provide a suitable installation environment for the products;
- damage caused by use of the Products for purposes other than those for which they were designed;
- damage from improper maintenance;
- damage arising out of any other abuse, mishandling or improper application of the Products.

Items Not Covered by Warranty: In addition to the items which void the Warranty, the following items shall not be covered by Warranty: (i) freight cost to the repair centre; (ii) customs fees, taxes, or VAT that may be due; (iii) Products which are not identified with the Seller's product label and lot number or serial number; (iv) Products disassembled or repaired in such a manner as to adversely affect performance or prevent adequate inspection or testing to verify any warranty claim. Access cards or tags returned for replacement under warranty will be credited or replaced at the Seller's option.

This warranty is exclusive and expressly in lieu of all other warranties, obligations or liabilities, whether written, oral, express or implied, including any warranty of merchantability or fitness for a particular purpose, or otherwise. In no case shall the SELLER be liable to anyone for any consequential or incidental damages for breach of this warranty or any other warranties whatsoever, as aforesaid.

The Seller shall in no event be liable for any special, indirect, incidental, consequential or punitive damages or for loss, damage, or expense, including loss of use, profits, revenue, or goodwill, directly or indirectly arising from Purchaser's use or inability to use the Product, or for loss or destruction of other property or from any other cause, even if Seller has been advised of the possibility of such damage.

The SELLER shall have no liability for any death, personal and/or bodily injury and/or damage to property or other loss whether direct, indirect, incidental, consequential or otherwise, based on a claim that the Product failed to function. However, if the Seller is held liable, whether directly or indirectly, for any loss or damage arising under this limited warranty, **the SELLER'S maximum liability (if any) shall not in any case exceed the purchase price of the Product INVOLVED**, which shall be fixed as liquidated damages and not as a penalty, and shall be the complete and exclusive remedy against the Seller.

When accepting the delivery of the Products, the buyer agrees to the said conditions of sale and warranty and he recognizes having been informed of.

Some jurisdictions do not allow the exclusion or limitation of incidental or consequential damages, so these limitations may not apply under certain circumstances.

The Seller shall be under no liability whatsoever arising out of the corruption and/or malfunctioning of any telecommunication or electronic equipment or any programs.

The Seller's obligations under this Warranty are limited solely to repair and/or replace at the Seller's discretion any Product or part thereof that may prove defective. Any repair and/or replacement shall not extend the original Warranty period. The Seller shall not be responsible for dismantling and/or reinstallation costs. To exercise this Warranty the Products must be returned to the Seller freight pre-paid and insured. All freight and insurance costs are the responsibility of the Buyer and are not included in this Warranty.

This warranty shall not be modified, varied or extended, and the Seller does not authorize any person to act on its behalf in the modification, variation or extension of this warranty. This warranty shall apply to the Products only. All products, accessories or attachments of others used in conjunction with the Products, including batteries, shall be covered solely by their own warranty, if any. The Seller shall not be liable for any damage or loss whatsoever, whether directly, indirectly, incidentally, consequentially or otherwise, caused by the malfunction of the Products due to products, accessories, or attachments of others, including batteries, used in conjunction with the Products. This Warranty is exclusive to the original Buyer and is not assignable.

This Warranty is in addition to and does not affect your legal rights. Any provision in this warranty which is contrary to the Law in the state or country where the Product is supplied shall not apply.

Governing Law: This disclaimer of warranties and limited warranty are governed by the domestic laws of Israel.

Warning

The user must follow the Seller's installation and operational instructions including testing the Product and its whole system at least once a week and to take all necessary precautions for his/her safety and the protection of his/her property.

	<p>W.E.E. Product Recycling Declaration For information regarding the recycling of this product you must contact the company from which you originally purchased it. If you are discarding this product and not returning it for repair then you must ensure that it is returned as identified by your supplier. <u>This product is not to be thrown away with everyday waste.</u> Directive 2012/96/EC Waste Electrical and Electronic Equipment.</p>
---	---

D-307895 LTE Communicator for PowerMaster-10, 30, 33 (Rev 1, 11/20)

EMAIL: info@visonic.com

Website: www.visonic.com



D-307895



