



MP-802 K9-85 PG2

Wireless Digital Pet Immune PIR Detector



Installation Instructions

1. INTRODUCTION

The MP-802 K9-85 PG2 (pet immune) is a microprocessor-controlled wireless digital PIR detector supported by the PowerMaster alarm system using PowerG two-way communication protocol.

The detector's features are as follows:

- Fresnel and cylindrical lenses with uniform detection sensitivity throughout its operating range, up to 12 meters (39 ft).
- Target Specific Imaging™ (TSI) technology is used for distinction between humans and pets weighing up to 38 kg (85lb).
- The advanced True Motion Recognition™ algorithm (patented) allows distinguishing between the true motion of an intruder and any other disturbances which may cause false alarms.
- No vertical adjustment is needed.
- Motion event counter determines whether 1 (high sensitivity) or 2 (low sensitivity) consecutive motion events trigger an alarm.
- Very low current consumption.
- Microprocessor-controlled temperature compensation.
- Front and back tamper protection.
- The device supports temperature and light level reports according to the PowerG panel.

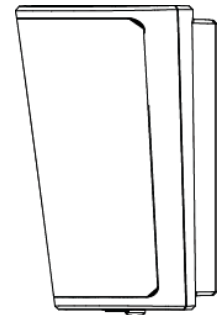

Figure 1: MP-802 K9-85 PG2

For UL installations: The detector is for use with UL listed control unit only. Pet immunity has not been evaluated by UL.

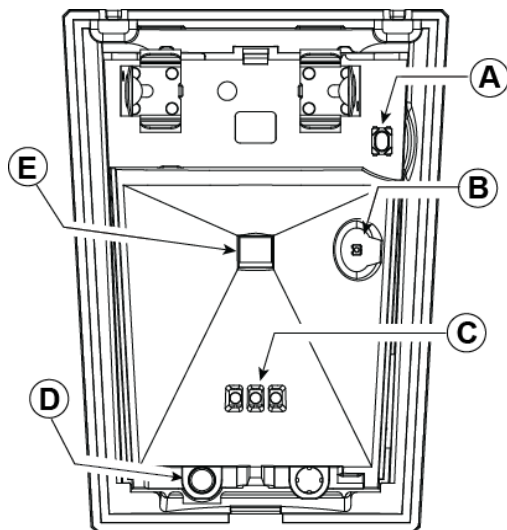

Figure 2 - Internal View

- A. Enroll button
- B. Light sensor
- C. LEDs
- D. Tamper switch
- E. PIR sensor

2. INSTALLATION

2.1. General Guidance

1. Keep away from heat sources.
2. Do not expose to air drafts.
3. Do not install outdoors.
4. Avoid direct sunshine.
5. Do not install near high-voltage electrical line.
6. Do not install behind partitions.
7. Mount on solid stable surface.

Warning! Do not obscure partially or completely the detector's field of view.

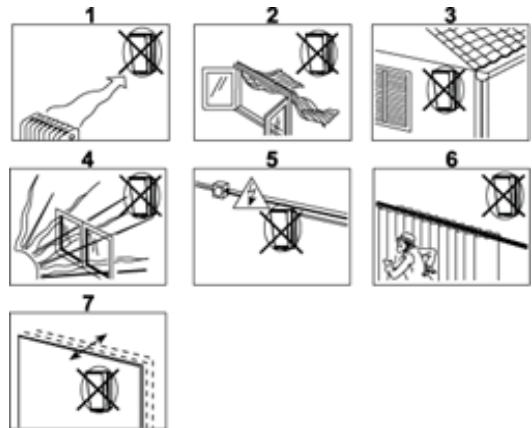

Figure 3 - General Guidelines

2.2. Installation Procedure

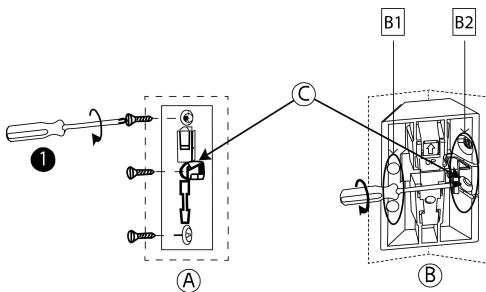

Figure 4 - Bracket Mounting

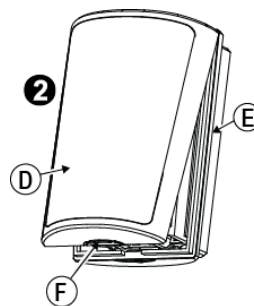

Figure 5 - Opening the Unit

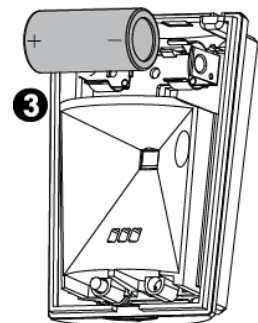

Figure 6a - Battery Insertion

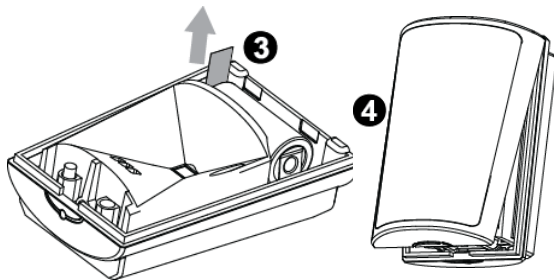

Figure 6b - Battery Activation

Figure 7 - Closing the Cover



Figure 8 - Securing with Screw

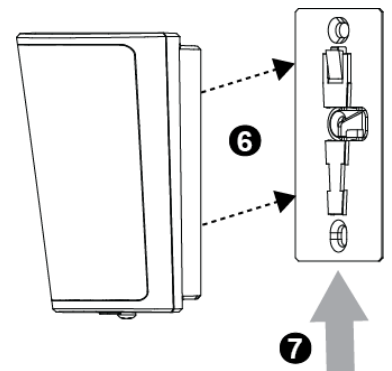

Figure 9 - Mounting Detector on Bracket

1. Mount the bracket on the wall.
2. Press in the point marked "F" in the drawing and separate the cover from the base.
3. Insert the battery while observing polarity-OR- If battery is already installed, pull the activation strip that protrudes from the front of the detector.
4. Return the cover to the base until a click is heard (the snap is closed).
5. Secure detector with screw.
6. Align the detector with the bracket.
7. Slide the detector upward until a click is heard.

- A. Surface mounting
- B. Corner mounting, use B1 or B2
- C. For back tamper
- D. Cover
- E. Base
- F. Press in this point

Note: The detector transmits a low battery signal upon detection of low voltage. It is recommended to wait about 1 minute after battery removal, before inserting the new battery.

MP-802 K9-85 shall be installed in accordance with the Standard for Installation and Classification of Burglar and Holdup Alarm Systems, UL 681.

Caution! Risk of explosion if battery is replaced by an incorrect type. Dispose of used battery according to the manufacturer's instructions.

2.3. Removing the Pet Mask

Remove the plastic (pet mask) if you do not require pet immunity.

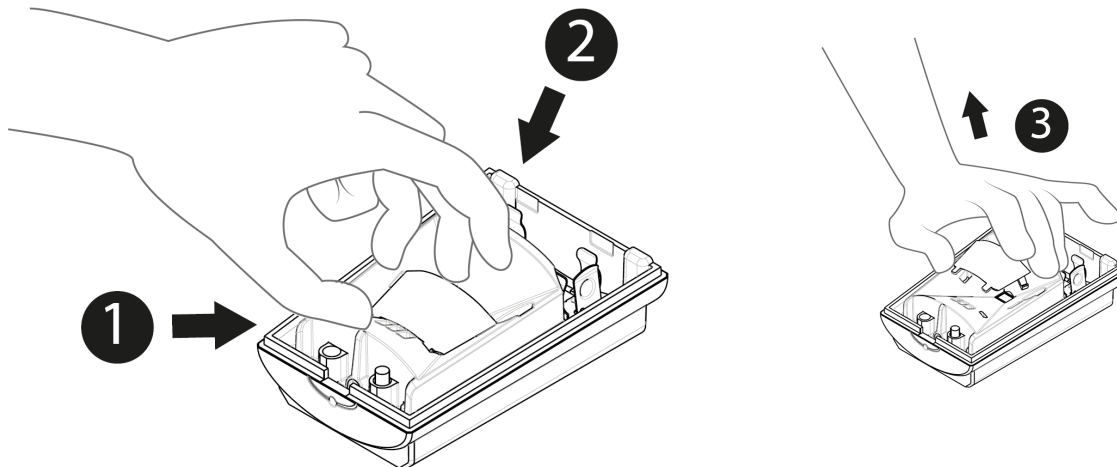

Figure 10 - Removing the Pet Mask

1. Place your thumb at the base of the Pet Mask.
2. Place your fingers at the top of the Pet Mask.
3. Lift the Pet Mask to remove.

2.4. Disassembly from Bracket



Figure 11 - Disassembly from Bracket

1. Release screw.
2. Separate the cover from the base.
3. Remove battery.
4. Press on the stopper snap to release the base from the bracket.
5. Slide the base downward to remove.

2.5. Enrollment

Refer to the PowerMaster panel's Installer Guide and follow the procedure under the "02:ZONES/DEVICES" option of the Installer Menu. A general description of the procedure is provided in the following flow chart.

For UL/ULC listed installations use only in conjunction with UL/ULC listed control panels: PowerMaster-10 and PowerMaster-30 G2.

Step	Procedure	Menu
1	Enter the installer menu and select "02:ZONES/DEVICES"	02:ZONES/DEVICES ADD NEW DEVICES
2	Select "ADD NEW DEVICES" Option – See Note [1]	↓ MODIFY DEVICES
3	Select "ADD NEW DEVICES" Option – See Note [1] Enroll the device or enter the device ID	ENROLL NOW or ENTR ID:XXX-XXXX

4	Select the desired Zone Number	Z14:Motion Sens (with panels PowerG V19.2 and lower) ID No. 120-XXXX (with panels PowerG V19.2 and lower) Z14:S.Motion (with panels PowerG V19.3 and higher) ID No. 126-XXXX (with panels PowerG V19.3 and higher)
5	Configure Location, Zone Type & Chime Parameters	Z14:LOCATION Z14:ZONE TYPE Z14:SET CHIME
6	Configure the detector	Z14 :DEV SETTINGS See Note 2

Notes:

[1] If the detector is already enrolled, you can configure the detector parameters via the modify devices option – see step 2.

[2] Select the “Device Settings” option and refer to section 3 to configure the detector parameters.

3. Temperature Display

For instructions on displaying the temperature of zones on the control panel as measured by MP-802 PG2 detectors, refer to the PowerMaster Installer Guide, section 4.2 “Conducting a Periodic Test”.

4. Configuring the Detector Parameters

Enter the **DEVICE SETTINGS** menu and follow the configuration instructions for the MCP-802 K9-85 PG2 detector as described in the following table.

Option	Configuring Instructions
Alarm LED	Define whether or not the alarm LED indication will be activated. Optional settings: LED ON (default) and LED OFF.
Event Counter	Define whether an alarm will be activated upon continued motion (low sensitivity) or upon a single alarm event (high sensitivity). Optional settings: LOW sensitive (default) and HIGH sensitive.
DISARM Activity	Define whether or not to set the activity time during disarm. Optional settings: NOT Active (default), YES – no delay, YES + 5s delay, YES + 15s delay, YES + 30s delay, YES + 1m delay, YES + 2m delay, YES + 5m delay, YES + 10m delay, YES + 20m delay and YES + 60m delay.
VERY HOT > 35°C [>95°F]	Define whether or not the control panel will report a "very hot" alert when the temperature rises above 35°C (95°F) for at least 10 minutes. Alert restore will occur when the temperature drops below 34°C (93°F) for the duration of 10 minutes. Optional settings: Disable (default) or Enable
COLD < 19°C [<66°F]*	Define whether or not the control panel will report a "cold" alert when the temperature drops below 19°C (66°F) for at least 10 minutes. Alert restore will occur when the temperature rises above 20°C (68°F) for the duration of 10 minutes. Optional settings: Disable (default) or Enable
FREEZING < 7°C [<45°F]*	Define whether or not the control panel will report a "freezing" alert when the temperature drops below 7°C (45°F) for at least 10 minutes. Alert restore will occur when the temperature rises above 8°C (48°F) for the duration of 10 minutes. Optional settings: Disable (default) or Enable
FREEZER > -10°C [<14°F)*	Define whether or not the control panel will report a "freezer" alert when the temperature rises above -10°C (14°F) for at least 30 minutes. Alert restore will occur when the temperature drops below -11°C (12°F) for the duration of 10 minutes. Optional settings: Disable (default) or Enable

Note: The temperature must pass beyond the threshold for the required duration in order to generate an alarm or restore transmission.

Note: The user can give access to installer to remotely enable or disable the indication led.

5. LOCAL DIAGNOSTICS TEST

Note: Run a diagnostic test at least once a year to ensure that the detector is working correctly.

1. Separate the base from the cover (see Figure 5).
2. Replace the cover to return the tamper switch to its normal (undisturbed) position, and then secure the front cover to the base with the case closure screw.
3. The MP-802 K9-85 PG2 detector will enter a 2 min. stability period. During this time the red LED blinks.

4. Walk-test the coverage area – see Figure 12. Walk across the far end of the coverage pattern in both directions. The red LED lights each time your motion is detected followed by 3 LED blinks.

The following table outlines received signal strength indication:

LED response	Reception
Green LED blinks	Strong
Orange LED blinks	Good
Red LED blinks	Poor
No blinks	No communication

Important! Instruct the user to walk test at least once a week to verify proper function of the detector.

Important! Reliable reception must be assured. Therefore, **poor** signal strength is not acceptable. If you receive a **poor** signal from the device, relocate it and re-test until a **good** or **strong** signal strength is received (in regions requiring UL-compliant installation, only **strong** signal strength is permitted).

Notes:

[1] For detailed diagnostics test instructions, refer to the control panel Installer Guide.

**This menu appears in PowerMaster V19.3 or above only. In earlier versions, this menu will appear only after completing the following procedure:

- a. Upgrade the PowerMaster control panel to V19.3 or above.
- b. Delete the MP-802 K9-85 PG2 detector from the PowerMaster control panel.
- c. Enroll the detector to the PowerMaster control panel again.

6. COMPLIANCE WITH STANDARDS



The MP-802 K9-85 PG2 complies with the following standards:

Europe: EN 300220, EN 301489, EN 60950-1, EN 50130-4, EN 50131-1, EN 50131-2-2 Grade 2 Class II, EN 50130-5, EN 50131-6 Type C

UK: The MP-802 K9-85 PG2 is suitable for use in systems installed to conform to PD6662:2010 at Grade 2 and environmental CLASS II. DD243 and BS8243.

The Power G peripheral devices have two-way communication functionality, providing additional benefits as described in the technical brochure. This functionality has not been tested to comply with the respective technical requirements and should therefore be considered outside the scope of the product's certification.



Certified by Applicata Test & Certification AS in accordance with EN 50131-2-2, EN 50131-5-3, EN 50131-6, EN 50130-4, EN 50130-5 Applicata T&C has certified only the 868 MHz variant of this product.

This device is in compliance with Directive 2014/53/EU. The full text of the DoC is available at: <http://www.visonic.com/download-center>.

USA: FCC-CFR 47 Part 15, UL- UL 639



Canada: IC-RSS 247, ULC – S306

Note: Only devices operating at 912-919 MHz are tested and listed by UL/ULC.

This device complies with Part 15 of the FCC Rules and with ISSED license-exempt RSS standard(s). Operation is subject to the following two conditions: (1) This device may not cause harmful interference, and (2) this device must accept any interference received, including interference that may cause undesired operation.

Le présent appareil est conforme aux CNR d'ISED applicables aux appareils radio exempts de licence. L'exploitation est autorisée aux deux conditions suivantes : (1) l'appareil ne doit pas produire de brouillage, et (2) l'utilisateur de l'appareil doit accepter tout brouillage radioélectrique subi, même si le brouillage est susceptible d'en compromettre le fonctionnement.

WARNING! Changes or modifications to this unit not expressly approved by the party responsible for compliance could void the user's authority to operate the equipment.

To comply with FCC and IC RF exposure compliance requirements, the device should be located at a distance of at least 20 cm from all persons during normal operation. The antennas used for this product must not be co-located or operated in conjunction with any other antenna or transmitter.

Le dispositif doit être placé à une distance d'au moins 20 cm à partir de toutes les personnes au cours de son fonctionnement normal. Les antennes utilisées pour ce produit ne doivent pas être situés ou exploités conjointement avec une autre antenne ou transmetteur.

Note: This equipment has been tested and found to comply with the limits for a Class B digital device, pursuant to part 15 of the FCC Rules. These limits are designed to provide reasonable protection against harmful interference in a residential installation. This equipment generates, uses and can radiate

radio frequency energy and, if not installed and used in accordance with the instructions, may cause harmful interference to radio communications. However, there is no guarantee that interference will not occur in a particular installation. If this equipment does cause harmful interference to radio or television reception, which can be determined by turning the equipment off and on, the user is encouraged to try to correct the interference by one or more of the following measures:

- Reorient or relocate the receiving antenna.
- Increase the separation between the equipment and receiver.
- Connect the equipment into an outlet on a circuit different from that to which the receiver is connected.
- Consult the dealer or an experienced radio/TV technician for help.

Cet équipement a été testé et jugé conforme aux limites s'appliquant à un appareil numérique de classe B, conformément à la Partie 15 des réglementations de la FCC. Ces limites ont été élaborées pour offrir une protection raisonnable contre les interférences nuisibles dans une installation résidentielle.

Cet équipement génère, utilise et peut émettre de l'énergie de fréquence radio et, s'il n'est pas installé et utilisé conformément aux instructions du fabricant, peut provoquer des interférences dangereuses pour les communications radio. Toutefois, rien ne garantit l'absence d'interférences dans une installation particulière. Si cet équipement provoque des interférences nuisibles au niveau de la réception radio ou télévision, ce qui peut être déterminé par la mise hors, puis sous tension de l'équipement, vous êtes invité à essayer de corriger les interférences en prenant les mesures suivantes:

- Réorientez ou déplacez l'antenne réceptrice.
- Augmentez la distance qui sépare l'équipement et le récepteur.
- Branchez l'équipement à une prise d'un circuit différent de celui auquel est branché le récepteur.
- Consultez le revendeur ou un technicien radio/télévision expérimenté pour obtenir de l'aide

7. Special Comments

Even the most sophisticated detectors can sometimes be defeated or may fail to warn due to: DC power failure / improper connection, malicious masking of the lens, tampering with the optical system, decreased sensitivity in ambient temperatures close to that of the human body and unexpected failure of a component part.

The above list includes the most common reasons for failure to detect intrusion, but is by no means comprehensive. It is therefore recommended that the detector and the entire alarm system be checked weekly, to ensure proper performance.

An alarm system should not be regarded as a substitute for insurance. Home and property owners or renters should be prudent enough to continue insuring their lives and property, even though they are protected by an alarm system.



W.E.E.E. Product Recycling Declaration

For information regarding the recycling of this product you must contact the company from which you originally purchased it. If you are discarding this product and not returning it for repair then you must ensure that it is returned as identified by your supplier. This product is not to be thrown away with everyday waste.

Directive 2002/96/EC Waste Electrical and Electronic Equipment.

8. SPECIFICATIONS

GENERAL

Detector Type Dual element low-noise pyroelectric sensor

OPTICAL

Lens Data

Fresnel and cylinder type lens with optical attenuation (PET mask) in the lower pattern part of the lens.

Number of beams/curtains: 27 Fresnel far (54 sensitivity "beams"), 18 Cylinder mid, 10 Cylinder close.

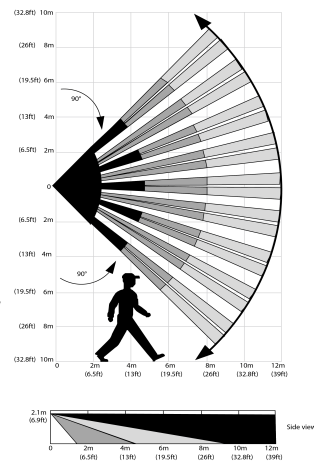

**Figure 12 – Coverage
Pattern Walk Test**

Max. coverage 12 x 12 m (39 x 39 ft) / 90°

Pet Immunity Up to 38 kg (85 lb)

ELECTRICAL

Power Supply Type C.

Internal Battery 3V Lithium battery, type CR-123A. For UL installations, use Panasonic and GP only

Nominal Battery Capacity 1450 mAh

Battery Life (typical use) Minimum 1 year. For typical use, 6 to 8 years (not verified by UL).

Low Battery Threshold 2.4 V

Note:

Inability to connect with wireless network, or wireless link quality no higher than 20% may significantly reduce the expected battery life

Performed immediately upon battery insertion and periodically after every several hours.

Battery Power Test

The power supply is type C in accordance with EN 50131-6 Documentation – Clause 6.

Current Consumption 10µA average quiescent , maximum 40mA (during transmission)

FUNCTIONALITY

True Motion Event Verification 2 remote selections at panel – LOW, HIGH

Alarm Period 2 seconds

LED Switch LED Enable (red LED lights for 2 sec. upon alarm detection)

WIRELESS

Europe and rest of world: 433-434 MHz, 868-869 MHz USA: 912-919 MHz

Frequency

Note: Only devices in frequency band 915 MHz are UL/ULC listed

Max Tx Power <10 dBm (433-434), <14dBm (868-869)

Communication Protocol PowerG

Supervision Signaling at 4-min. intervals

Tamper Alert Reported when a tamper event occurs and in any subsequent message, until the tamper switch is restored

MOUNTING

Height

1.8-2.4 m (6 - 8 ft.). For pet rejection, the optimal height is 2.1 m (7 ft.)

At 2.4m (7.87 ft.) height installation, remove pet mask as pet immunity is not supported.

Installation Options Surface or corner

ENVIRONMENTAL

RF Immunity 20 V/m up to 1000 MHz, 10 V/m up to 2700 MHz

Operating Temperatures -10°C to 50°C (14°F to 122°F). Note: UL verified operation range 0°C to 49°C only.

Storage Temperatures	-20°C to 60°C (-4°F to 140°F)
Humidity	Average relative humidity of up to approximately 75% non-condensing. For 30 days per year the relative humidity may vary between 85% and 95% non-condensing. For UL installations: 5 % to 93 % with no condensation
PHYSICAL	For indoor use only.
Size (H x W x D)	83 x 61 x 42 mm (3.27 x 2.4 x 1.66")
Weight (with battery)	90 g (3.17 oz)
Color	White
PATENTS	U.S. Patents 5,693,943 • 6,211,522

WARRANTY

Visonic Limited (the "Manufacturer") warrants this product only (the "Product") to the original purchaser only (the "Purchaser") against defective workmanship and materials under normal use of the Product for a period of twelve (12) months from the date of shipment by the Manufacturer.

This Warranty is absolutely conditional upon the Product having been properly installed, maintained and operated under conditions of normal use in accordance with the Manufacturers recommended installation and operation instructions. Products which have become defective for any other reason, according to the Manufacturers discretion, such as improper installation, failure to follow recommended installation and operational instructions, neglect, willful damage, misuse or vandalism, accidental damage, alteration or tampering, or repair by anyone other than the manufacturer, are not covered by this Warranty.

The Manufacturer does not represent that this Product may not be compromised and/or circumvented or that the Product will prevent any death and/or personal injury and/or damage to property resulting from burglary, robbery, fire or otherwise, or that the Product will in all cases provide adequate warning or protection. The Product, properly installed and maintained, only reduces the risk of such events without warning and it is not a guarantee or insurance that such events will not occur.

THIS WARRANTY IS EXCLUSIVE AND EXPRESSLY IN LIEU OF ALL OTHER WARRANTIES, OBLIGATIONS OR LIABILITIES, WHETHER WRITTEN, ORAL, EXPRESS OR IMPLIED, INCLUDING ANY WARRANTY OF MERCHANTABILITY OR FITNESS FOR A PARTICULAR PURPOSE, OR OTHERWISE. IN NO CASE SHALL THE MANUFACTURER BE LIABLE TO ANYONE FOR ANY CONSEQUENTIAL OR INCIDENTAL DAMAGES FOR BREACH OF THIS WARRANTY OR ANY OTHER WARRANTIES WHATSOEVER, AS AFORESAID. THE MANUFACTURER SHALL IN NO EVENT BE LIABLE FOR ANY SPECIAL, INDIRECT, INCIDENTAL, CONSEQUENTIAL OR PUNITIVE DAMAGES OR FOR LOSS, DAMAGE, OR EXPENSE, INCLUDING LOSS OF USE, PROFITS, REVENUE, OR GOODWILL, DIRECTLY OR INDIRECTLY ARISING FROM PURCHASER'S USE OR INABILITY TO USE THE PRODUCT, OR FOR LOSS OR DESTRUCTION OF OTHER PROPERTY OR FROM ANY OTHER CAUSE, EVEN IF MANUFACTURER HAS BEEN ADVISED OF THE POSSIBILITY OF SUCH DAMAGE.

THE MANUFACTURER SHALL HAVE NO LIABILITY FOR ANY DEATH, PERSONAL AND/OR BODILY INJURY AND/OR DAMAGE TO PROPERTY OR OTHER LOSS WHETHER DIRECT, INDIRECT, INCIDENTAL, CONSEQUENTIAL OR OTHERWISE, BASED ON A CLAIM THAT THE PRODUCT FAILED TO FUNCTION.

However, if the Manufacturer is held liable, whether directly or indirectly, for any loss or damage arising under this limited warranty, **THE MANUFACTURER'S MAXIMUM LIABILITY (IF ANY) SHALL NOT IN ANY CASE EXCEED THE PURCHASE PRICE OF THE PRODUCT**, which shall be fixed as liquidated damages and not as a penalty, and shall be the complete and exclusive remedy against the Manufacturer.

When accepting the delivery of the Product, the Purchaser agrees to the said conditions of sale and warranty and he recognizes having been informed of.

Some jurisdictions do not allow the exclusion or limitation of incidental or consequential damages, so these limitations may not apply under certain circumstances.

The Manufacturer shall be under no liability whatsoever arising out of the corruption and/or malfunctioning of any telecommunication or electronic equipment or any programs.

The Manufacturers obligations under this Warranty are limited solely to repair and/or replace at the Manufacturer's discretion any Product or part thereof that may prove defective. Any repair and/or replacement shall not extend the original Warranty period. The Manufacturer shall not be responsible for dismantling and/or reinstallation costs. To exercise this Warranty the Product must be returned to the Manufacturer freight pre-paid and insured. All freight and insurance costs are the responsibility of the Purchaser and are not included in this Warranty.

This warranty shall not be modified, varied or extended, and the Manufacturer does not authorize any person to act on its behalf in the modification, variation or extension of this warranty. This warranty shall apply to the Product only. All products, accessories or attachments of others used in conjunction with the Product, including batteries, shall be covered solely by their own warranty, if any. The Manufacturer shall not be liable for any damage or loss whatsoever, whether directly, indirectly, incidentally, consequentially or otherwise, caused by the malfunction of the Product due to products, accessories, or attachments of others, including batteries, used in conjunction with the Products. This Warranty is exclusive to the original Purchaser and is not assignable.

This Warranty is in addition to and does not affect your legal rights. Any provision in this warranty which is contrary to the Law in the state or country where the Product is supplied shall not apply.

Warning: The user must follow the Manufacturer's installation and operational instructions including testing the Product and its whole system at least once a week and to take all necessary precautions for his/her safety and the protection of his/her property.



A Tyco International Company

Email: info@visonic.com

Internet: www.visonic.com

© VISONIC LTD. 2017 MP-802 K9-85 PG2 D-306133 (Rev. 2 05/17)