



D-303089

English

# SR-720 PG2

## Wireless PowerG Indoor Siren



## Installation Instructions

### 1. INTRODUCTION

The SR-720 PG2 is a full 2-way wireless PowerG indoor siren, designed for installation in areas in which wiring action is difficult or impossible.

#### Features

- **Siren and strobe light activation:** When an identified event message is received from the compatible PowerG alarm system, the siren activates its sounder & strobe light.

#### Notes:

*The sounder is activated for a predefined "Bell Time" (refer to the control panel Installer Guide), according to local authorities requirements, or until the system is disarmed, whichever occurs first.*

*The strobe light operates as described in the control panel Installer Guide.*

- **Tamper indication:** In case of tamper while the system is armed, the siren transmits the message to the alarm system and then the alarm system determines whether the siren should be activated or not. If the siren does not receive an acknowledge message from the alarm system, the siren will function independently.
- **Low battery voltage alert:** When the battery voltage is low, a low battery message is sent to the alarm system. After the low voltage message delivery, at least 2 siren alarms are possible before the siren is totally inactive.

- **Power Supply:** Non-rechargeable battery.
- **Sound Types:** Burglar (between 1400Hz - 3200Hz), fire, gas(CO) and flood.
- **Entry/Exit:** Exit delay beeps sound once the user has armed the system. Entry delay beeps sound once the user has entered the protected area. (Entry/exit beeps can be enabled / disabled from the control panel Installer menu.)
- **Squawk indications:** Squawk (beep) sounds can be used to indicate alarm system arming (1 squawk) and disarming (2 squawks) by a keyfob (squawk can be enabled from the control panel User menu).
- **Double Tamper protection:** When the siren front panel is removed or when the siren is removed from the wall, tamper alarm is sent to the alarm system.
- **2-way full supervision**

The siren is a fully supervised, 2-way communication device. It includes a receiver, to receive event messages from the alarm system, and a transmitter, to periodically transmit its status signal to the alarm system.

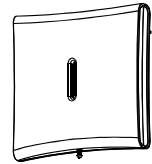

Fig. 1 - External View

#### Self-test feature

Upon pressing the self test switch, siren functional check is performed - low level sounds and flash light indicate that the siren is serviceable.

### 2. INSTALLATION

#### 2.1 Installation

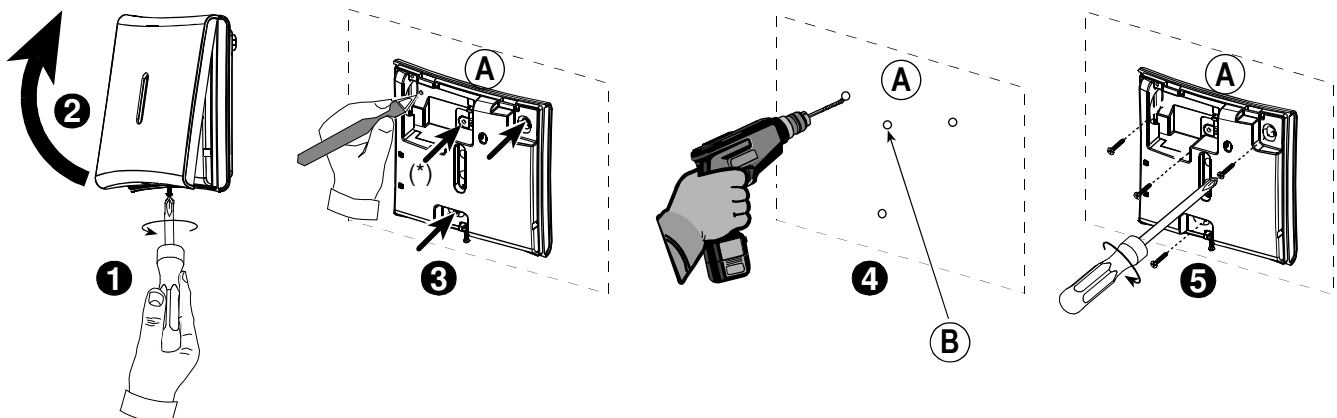

1. Open plastic cover screw.
  2. Using Philips screwdriver, remove screw and remove cover.
  3. Mark for drilling.
  4. Drill 4 holes.
  - 5 Fasten with 4 screws.
- A. Mounting surface.  
B. For back tamper screw.

Figure 2: Installation

## 2.2 Battery Pack Insertion

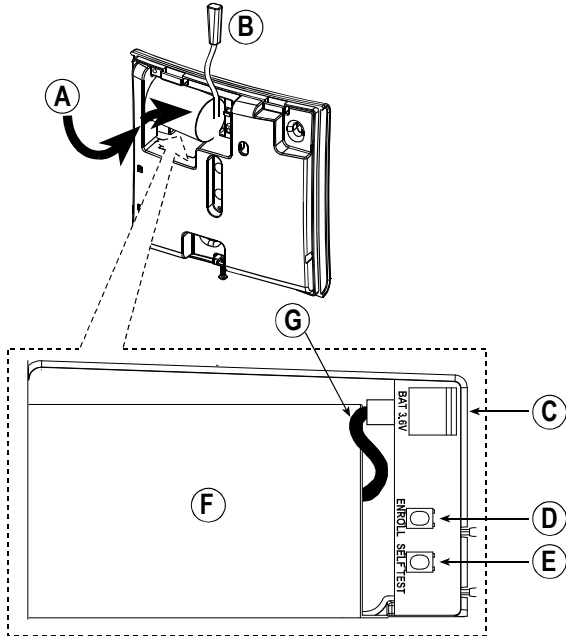

- A. Turn and push battery
- B. Battery pack connector
- C. Battery connector
- D. Enroll button
- E. Self test switch
- F. Battery
- G. Battery cable

Figure 3: Battery Pack Insertion

## 2.3 Cover Closure

See Figure 4.

1. Put back the plastic cover.
2. Secure with screw.

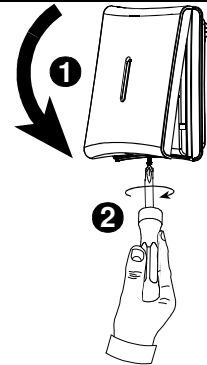

Figure 4 - Cover Closure

### CAUTION!

Risk of explosion if battery is replaced by an incorrect type. Dispose of used battery according to manufacturer's instructions.

## 3. ENROLLMENT

Refer to the control panel Installer Guide for the device enrollment procedure.

## 4. SR-720 PG2 DEVICE SETTINGS

This section describes how to configure the parameters of the siren from the control panel.

### To Modify the Siren Device Settings

Refer to the control panel Installer Guide and perform the procedure for Adding A Wireless Device (section 4.5.2), or, Modifying a Device (section 4.5.5). Then continue below to modify the device settings.

1. **DEV SETTINGS**  

  - STROBE ALARM**
2. 
  - Timer limited
3.  or 
  - STROBE ALARM**
4. 
  - EXIT-ENTRY Beeps
5. 
  - EXIT-ENTRY Beeps
6. 
  - OFF
7.  or 
  - EXIT-ENTRY Beeps
8. 
  - EXIT-ENTRY Beeps
9. 
  - SQUAWK
10. 
  - Disabled

Here you determine whether or not to activate the strobe alarm, and if to activate whether to activate the strobe until the alarm system is disarmed, or, for the programmed period of time (see section "Siren Configuration" in the control panel Installer Guide).

Select between "Timer limited", "Disabled" and "Until Disarmed".

Here you determine whether or not to activate the exit – entry beeps, and if enabled, whether to activate in HOME or AWAY mode.

Select between "OFF", "OFF & Home" and "ON".

Here you determine whether or not to activate the squawk, and if enabled, whether to activate the sounder only, or, the sounder and strobe simultaneously.

11. or Select between "Disabled", "Sounder only", "Strobe only" and "Sounder+strobe".
12. **OK**
13. **SQUAWK**  
 Here you determine the volume level of the sounder.
14. **OK**  
 **SOUNDER VOLUME**  
Maximum
15. or Select between "Maximum", "Minimum" and "Medium".
16. **OK**  
**Note:** For UL Listed product, set to "Maximum".
17. **SOUNDER VOLUME**  
 Here you determine whether or not the siren alone will sound a tamper alarm when there is no communication between the siren and the control panel.
18. **OK**  
 **DISABLED**
19. or Select between "Disabled" and "Enabled".
20. **OK**  
**AUTO TAMPER ALARM**

When exiting "INSTALLER MODE" menu, the alarm system displays the number of devices that need to be updated, as follows: "DEV UPDATING MNM". For detailed instructions on Adding Devices, Deleting Devices, Replacing Devices and Defining Defaults see the control panel Installer Guide.

## 5. LOCAL DIAGNOSTICS TEST

Before testing, remove the plastic cover and then open the battery cover (see Fig. 2).

- A.** Press the self-test button (see Fig. 3) once and release it; the following procedure should occur in turn:  
The red LED will switch ON and then OFF, the green LED will switch ON and then OFF, the strobe light will switch ON and then OFF and the piezo siren will sound to indicate that the siren is now fully operational.
- B.** After 2 seconds the LED blinks 3 times.  
The following table indicates received signal strength indication.

LED response	Reception
Green LED blinks	Strong
Orange LED blinks	Good
Red LED blinks	Poor
No blinks	No communication

**IMPORTANT!** Reliable reception must be assured. Therefore, "poor" signal strength is not acceptable. If you receive a "poor" signal from the device, re-locate it and re-test until a "good" or "strong" signal strength is received.

- For detailed Diagnostics Test instructions refer to the control panel Installer Guide.
- For UL/CUL installations, the test result must be "Strong".

## 6. COMPLIANCE WITH STANDARDS

### Compliance with Standards



**Europe:** EN50131-1 Grade 2 Class 2, EN 50131-4, EN 301489, EN 50130-4, EN 50130-5, EN 300 220, EN 60950-1, EN 60950-22

**UK:** This product is suitable for use in systems installed to conform to PD6662:2010 at Grade 2 and environmental class 2. DD243 and BS8243

The SR-720 PG2 is compatible with the RTTE requirements - Directive 1999/5/EC of the European Parliament and of the Council of 9 March 1999 and EN50131-1 Grade 2 Class II.

Certified by Norwegian accredited certification body Applica Test & Certification AS in accordance with EN 50131-4, EN 50131-6, EN 50131-5-3, EN 50130-4, and EN 50130-5.

Applica T&C has certified only the 868 MHz variant of this product.

**USA:** CFR 47 Part 15 (FCC)

**Canada:** RSS 210

The Power G peripheral devices have two-way communication functionality, providing additional benefits as described in the technical brochure. This functionality has not been tested to comply with the respective technical requirements and should therefore be considered outside the scope of the product's certification.

According to EN 50131-1:2006 and A1:2009, this equipment can be applied in installed systems up to and including Security Grade 2.

Class II

EN 50131-1 Security Grade

EN 50131-1 Environmental Class

The digital circuit of this device has been tested and found to comply with the limits for a Class B digital device, pursuant to Part 15 of the FCC Rules. These limits are designed to provide reasonable protection against harmful interference in residential installations. This equipment generates, uses and can radiate radio frequency energy and, if not installed and used in accordance with the instructions, may cause harmful interference to radio and television reception. However, there is no guarantee that interference will not occur in a particular installation. If this device does cause such interference, which can be verified by turning the device off and on, the user is encouraged to eliminate the interference by one or more of the following measures:

- Re-orient or re-locate the receiving antenna.
- Increase the distance between the device and the receiver.
- Connect the device to an outlet on a circuit different from the one which supplies power to the receiver.
- Consult the dealer or an experienced radio/TV technician.

**Note:** The manufacturer is not responsible for any radio or TV interference caused by unauthorized modifications to this equipment. Such modifications could void the user's authority to operate the equipment.

**WARNING!** Changes or modifications to this unit not expressly approved by the party responsible for compliance could void the user's authority to operate the equipment.

This device complies with FCC Rules Part 15 and with Industry Canada licence-exempt RSS standard(s). Operation is subject to two conditions: (1) This device may not cause harmful interference, and (2) this device must accept any interference that may be received or that may cause undesired operation.

Le présent appareil est conforme aux CNR d'Industrie Canada applicables aux appareils radio exempts de licence. L'exploitation est autorisée aux deux conditions suivantes : (1) l'appareil ne doit pas produire de brouillage, et (2) l'utilisateur de l'appareil doit accepter tout brouillage radioélectrique subi, même si le brouillage est susceptible d'en compromettre le fonctionnement.

	<p><b>W.E.E.E. Product Recycling Declaration</b>                  For information regarding the recycling of this product you must contact the company from which you originally purchased it. If you are discarding this product and not returning it for repair then you must ensure that it is returned as identified by your supplier. <u>This product is not to be thrown away with everyday waste.</u>                  Directive 2002/96/EC Waste Electrical and Electronic Equipment.</p>
-----------------------------------------------------------------------------------	-----------------------------------------------------------------------------------------------------------------------------------------------------------------------------------------------------------------------------------------------------------------------------------------------------------------------------------------------------------------------------------------------------------------------------------------------------------------------------------------------------------

## 7. SPECIFICATIONS

**Frequency Band (MHz):** Europe: 433, 868, USA: 915\*

**Note:** For UL Listed Product, enable this frequency band.

**Modulation:** GFSK

**Antenna:** Built-in antenna

**Communication Protocol:** PowerG

**Siren Type:** At least 85 dBA at 10 ft (3 m).

**Sound Pressure Level @ 1m, 1400Hz – 3200 Hz, sweep frequency 7 Hz.**

**Battery Type:** 3.6V/1300mA/H Lithium battery (EVE ER34615M/w200), Visonic assembly cat. No. 0-9912-K.

**Note:** Use only the above battery.

**Note:** The strobe flashes 5 times and the red LED lights continuously during first battery installation.

**Battery Life Expectancy:** 8 years (for typical use)

**Low Battery Threshold:** 2 V +300 mV negative slope OR 1.2 V

**Strobe Light:** Pulsed @ 1 sec.

**Operating Temperature:** -10°C to 60°C (-14°F to 140°F)

**Note:** For UL Listed product, the ambient temperature is 32°F to 120°F (0°C to 49°C), Relative Humidity 93%

**Dimensions (LxWxD):** 161x161x50mm (6-7/16 x 6-7/16 x 1-3/4 in)

**Weight (including battery):** 470g (16.5 oz.)

**Color:** White (with transparent lens)

### WARRANTY

Visonic Limited (the "Manufacturer") warrants this product only (the "Product") to the original purchaser only (the "Purchaser") against defective workmanship and materials under normal use of the Product for a period of twelve (12) months from the date of shipment by the Manufacturer.

This Warranty is absolutely conditional upon the Product having been properly installed, maintained and operated under conditions of normal use in accordance with the Manufacturers recommended installation and operation instructions. Products which have become defective for any other reason, according to the Manufacturers discretion, such as improper installation, failure to follow recommended installation and operational instructions, neglect, willful damage, misuse or vandalism, accidental damage, alteration or tampering, or repair by anyone other than the manufacturer, are not covered by this Warranty.

The Manufacturer does not represent that this Product may not be compromised and/or circumvented or that the Product will prevent any death and/or personal injury and/or damage to property resulting from burglary, robbery, fire or otherwise, or that the Product will in all cases provide adequate warning or protection. The Product, properly installed and maintained, only reduces the risk of such events without warning and it is not a guarantee or insurance that such events will not occur.

**THIS WARRANTY IS EXCLUSIVE AND EXPRESSLY IN LIEU OF ALL OTHER WARRANTIES, OBLIGATIONS OR LIABILITIES, WHETHER WRITTEN, ORAL, EXPRESS OR IMPLIED, INCLUDING ANY WARRANTY OF MERCHANTABILITY OR FITNESS FOR A PARTICULAR PURPOSE, OR OTHERWISE. IN NO CASE SHALL THE MANUFACTURER BE LIABLE TO ANYONE FOR ANY CONSEQUENTIAL OR INCIDENTAL DAMAGES FOR BREACH OF THIS WARRANTY OR ANY OTHER WARRANTIES WHATSOEVER, AS AFORESAID.**

**THE MANUFACTURER SHALL IN NO EVENT BE LIABLE FOR ANY SPECIAL, INDIRECT, INCIDENTAL, CONSEQUENTIAL OR PUNITIVE DAMAGES OR FOR LOSS, DAMAGE, OR EXPENSE, INCLUDING LOSS OF USE, PROFITS, REVENUE, OR GOODWILL, DIRECTLY OR INDIRECTLY ARISING FROM PURCHASER'S USE OR INABILITY TO USE THE PRODUCT, OR FOR LOSS OR DESTRUCTION OF OTHER PROPERTY OR FROM ANY OTHER CAUSE, EVEN IF MANUFACTURER HAS BEEN ADVISED OF THE POSSIBILITY OF SUCH DAMAGE.**

**THE MANUFACTURER SHALL HAVE NO LIABILITY FOR ANY DEATH, PERSONAL AND/OR BODILY INJURY AND/OR DAMAGE TO PROPERTY OR OTHER LOSS WHETHER DIRECT, INDIRECT, INCIDENTAL, CONSEQUENTIAL OR OTHERWISE, BASED ON A CLAIM THAT THE PRODUCT FAILED TO FUNCTION.**

However, if the Manufacturer is held liable, whether directly or indirectly, for any loss or damage arising under this limited warranty, **THE MANUFACTURER'S MAXIMUM LIABILITY (IF ANY) SHALL NOT IN ANY CASE EXCEED THE PURCHASE PRICE OF THE PRODUCT**, which shall be fixed as liquidated damages and not as a penalty, and shall be the complete and exclusive remedy against the Manufacturer.

When accepting the delivery of the Product, the Purchaser agrees to the said conditions of sale and warranty and he recognizes having been informed of.

Some jurisdictions do not allow the exclusion or limitation of incidental or consequential damages, so these limitations may not apply under certain circumstances.

The Manufacturer shall be under no liability whatsoever arising out of the corruption and/or malfunctioning of any telecommunication or electronic equipment or any programs.

The Manufacturers obligations under this Warranty are limited solely to repair and/or replace at the Manufacturer's discretion any Product or part thereof that may prove defective. Any repair and/or replacement shall not extend the original Warranty period. The Manufacturer shall not be responsible for dismantling and/or reinstallation costs. To exercise this Warranty the Product must be returned to the Manufacturer freight pre-paid and insured. All freight and insurance costs are the responsibility of the Purchaser and are not included in this Warranty.

This warranty shall not be modified, varied or extended, and the Manufacturer does not authorize any person to act on its behalf in the modification, variation or extension of this warranty. This warranty shall apply to the Product only. All products, accessories or attachments of others used in conjunction with the Product, including batteries, shall be covered solely by their own warranty, if any. The Manufacturer shall not be liable for any damage or loss whatsoever, whether directly, indirectly, incidentally, consequentially or otherwise, caused by the malfunction of the Product due to products, accessories, or attachments of others, including batteries, used in conjunction with the Products. This Warranty is exclusive to the original Purchaser and is not assignable. This Warranty is in addition to and does not affect your legal rights. Any provision in this warranty which is contrary to the Law in the state or country where the Product is supplied shall not apply.

**Warning:** The user must follow the Manufacturer's installation and operational instructions including testing the Product and its whole system at least once a week and to take all necessary precautions for his/her safety and the protection of his/her property.

1/08



EMAIL: [info@visonic.com](mailto:info@visonic.com)  
 INTERNET: [www.visonic.com](http://www.visonic.com)  
 ©VISONIC LTD. 2015 D-303089 SR-720 PG2 (REV. 3, 6/15)



D-303089